

PB 400 ParkPro (W)

Professional tool for the park.



PRODUCT HIGHLIGHTS

- ⊕ Clean 6-cylinder engine with 435 metric HP (320 kW) and powerful torque (Tier 4f and EU Stage V)
- ⊕ Intuitive joystick for proportional control of 4 blade functions at the same time
- ⊕ iTerminal with touch display and color-coded function feedback of the active vehicle parts for easy operation
- ⊕ Storage of 4 driver settings with flexible joystick button assignment for park construction
- ⊕ Precise, proportional auxiliary hydraulics
- ⊕ Assistance systems such as AutoTracer, ActiveWinch and AutoWinch for ideal grooming results, side hold and maneuverability
- ⊕ ParkPro rear implement carrier with enlarged movement radius, vibration compensation and lateral damping for greater driving comfort
- ⊕ NoDeck version for the best view of the SmartCut tiller in park construction
- ⊕ Professional sound package with subwoofers and amplifiers
- ⊕ Optimized comfort seats for long journeys
- ⊕ Practical holders for backpack, tool and smartphone
- ⊕ The best panoramic view thanks to dimmable LED worklights, a rear camera and ramp mirrors

CAB

Comfort heating system	With automatic function and stepless temperature adjustment
Comfort driver's seat	With lordosis support, air-suspended, multiple mechanical and pneumatic adjustment positions, two-stage seat heating unit and seat ventilation, harness
Control elements	Joystick for 4 simultaneous movements, iTerminal, armrest, drive control stick
Windows	Windshield and rear window heated, side windows sliding and heated
Outside mirrors	Heated and electrically adjustable, wide-angle
Wipers	Coolant-heated, windshield washer system (winch only)

LIGHTING

Front	4 LED headlights 2 LED worklights 2 LED worklights (BladeFlap)
Rear	4 LED worklights (2 of which are for the camera and light mounting frame) 2 LED worklights (TillerFlap)
Sides (carrier frame)	2 LED worklights (SideFinder)
Cab roof	1 halogen or 1 LED searchlight

AUXILIARY EQUIPMENT

ProBlade 4.7 m	OneTouchStraight function, SideCutter, transport tines
ProFlexTiller SmartCut 5.5 m	With SmartCut tiller teeth and finishers, freeze function, dimmable lighting and camera, all positions hydraulically adjustable
ProMount	Swap system with radial kinematics and towing installation for a greater movement radius in park construction

OPTIONS

Automatic luxury climate control system	Central locking
Auxiliary seat with shoulder lap belt	Steering wheel control
Solid rubber wheels (only Solo)	Optional standard loading platform
Front high-pressure connection (technology package)	SnowSat fleet management and snow depth measurement with LiDAR
Hydraulic oil preheating	Auxiliary heating
Infotainment with Apple CarPlay and Android Auto	Folding side rail (requires standard loading platform)

PB 400 ParkPro (W)

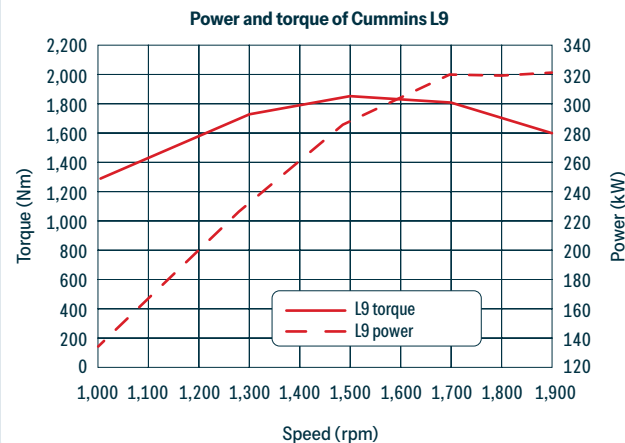
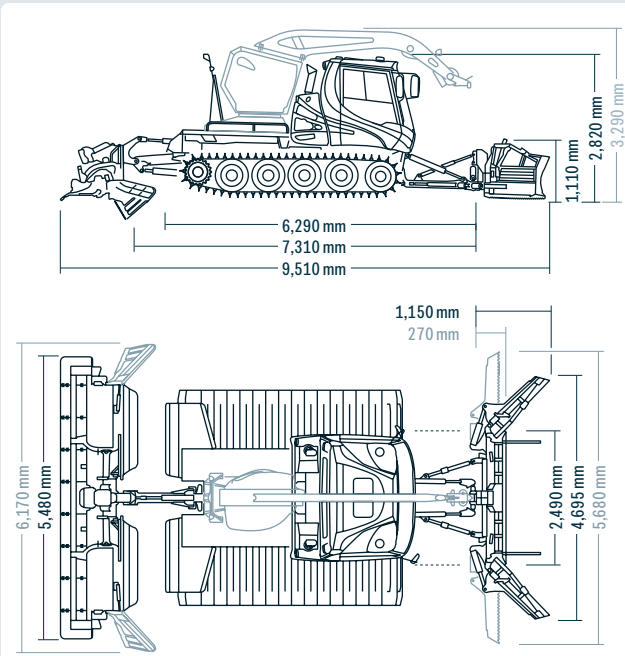

DIMENSIONS

Width	Without tracks and fenders	2,490 mm
	Over X-track tracks 1,150 mm	3,500 mm
	Over X-track tracks 1,420 mm	3,770 mm
Height	Over 6-belt CombiPlus Tracks 1,648 mm	4,210 mm
	Total Solo	2,820 mm
	Ready for operation via winch	3,290 mm
	Folded down via winch	3,020 mm
Loading platform (in place of NoDeck)	Width	1,920 mm
	Length	2,120 mm
Ground clearance		350 mm

WEIGHTS (FROM)

	400 PP	400 PP W
Empty weight	Vehicle without tracks / quick-change system	6,320 kg
	X-track chains 1,150 mm	1,360 kg
	X-track chains 1,420 mm	2,040 kg
Operating weight*	6-belt CombiPlus Tracks 1,648 mm	2,100 kg
	Vehicle with CombiPlus tracks/all way blade/tiller	from 10495 kg
Permitted gross weight (in accordance with ROPS)	13,500 kg	14,200 kg
Payload, load platform	NoDeck	2,500 kg
Power-to-weight ratio	32.8 kg/kW	40.6 kg/kW

*Minimum operating weight (according to standard)

ENGINE

Type	Cummins L9
Number of cylinders	6
Displacement	8,900 cm ³
Power in accordance with ECE	320 kW / 435 hp (metric)
Exhaust gas standard	Tier 4f/EU Stage V/China IV
Max. torque	1,846 Nm @ 1,500 rpm
Tank capacity Solo/NoDeck/winch	360 l/350 l/360 l
DEF (AdBlue®) tank capacity	36 l
Fuel consumption	from 19.5 l/h

DRIVING CHARACTERISTICS

	400 ParkPro	400 ParkPro W
Speed	0 - 19 km/h stepless	0 - 19 km/h stepless
Speed during winch operation		0 - 17 km/h
Climbing ability		Up to 100%
Turning radius		On the spot

ACTIVEWINCH 4.0 WINCH ATTACHMENT

Pulling force stepless, automatic	40 kN / 4 t
Rope diameter	11 mm
Rope length	1,050 m
Usable rope length	1,000 m
Calculated breaking load of the rope	135 kN / 13.8 t
Weight (winch, rope and mount)	2,090 kg



Contact

Fast. Direct. In person.
Find your contact person here.

www.pistenbully.com



KÄSSBOHRER ALL TERRAIN VEHICLES INC.