

PB 400 (W)

Multi-talent for slopes, trails, buildings and parks.



PRODUCT HIGHLIGHTS

- ⊕ Clean 6-cylinder engine with 435 metric HP (320 kW) and powerful torque (Tier 4f and EU Stage V)
- ⊕ Intuitive joystick for proportional control of 4 blade functions at the same time
- ⊕ iTerminal with touch display and color-coded function feedback of the active vehicle parts for easy operation
- ⊕ Storage of 4 driving settings
- ⊕ Precise, proportional auxiliary hydraulics
- ⊕ Assistance systems such as AutoTracer, ActiveWinch and AutoWinch for ideal grooming results, side hold and maneuverability
- ⊕ Rear implement carrier with vibration compensation and lateral damping for greater driving comfort
- ⊕ Large loading platform as a third storage space
- ⊕ Optimized comfort seats for long journeys
- ⊕ Practical holders for backpack, tool and smartphone
- ⊕ The best panoramic view thanks to halogen/LED Lighting, a rear camera and ramp mirrors

CAB

Comfort heating system	With automatic function and stepless temperature adjustment
Comfort driver's seat	With lordosis support, air-suspended, multiple mechanical and pneumatic adjustment positions, two-stage seat heating unit and seat ventilation, harness (only winch)
Control elements	Joystick for 4 simultaneous movements, iTerminal, armrest, steering wheel control
Windows	Windshield and rear window heated, side windows sliding and heated
Outside mirrors	Heated and electrically adjustable, wide-angle
Wipers	Coolant-heated, windshield washer system (winch only)

LIGHTING

Front	4 halogen headlights 2 halogen worklights 2 halogen worklights (BladeFlap)
Rear	4 halogen worklights (2 of which are for the camera and light mounting frame) 2 LED worklights (TillerFlap)
Sides (carrier frame)	2 LED worklights (SideFinder)
Cab roof	1 halogen or 1 LED searchlight

AUXILIARY EQUIPMENT

AllWayBlade 4.4 m	With / without snowgun holder
AlpinFlex tiller SmartCut 5.5 m	With SmartCut tiller teeth and finishers, dimmable lighting and camera
QCS	Swap system with parallel kinematics for easy slope grooming

OPTIONS

Trailer hitch	NoDeck version
Automatic luxury climate control system	NordicFlexTiller
Auxiliary seat with shoulder lap belt	Passenger cabins
Solid rubber wheels (only Solo)	ProMount
Front high-pressure connection (technology package)	Professional sound package (subwoofers and amplifiers)
Hydraulic oil preheating	Auxiliary heating
Infotainment with Apple CarPlay and Android Auto	SnowSat fleet management and snow depth measurement with LiDAR
Folding side rail (requires incline sensor)	LED light package with dimmable worklights
Drive control stick	Central locking
Tracking plates with / without track tiller	Additional tank 120 L

PB 400 (W)

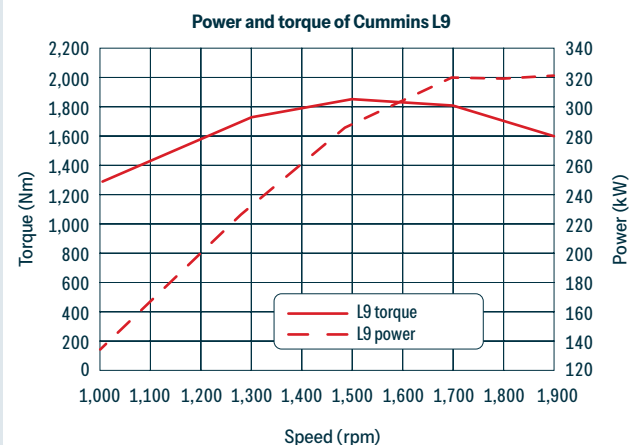
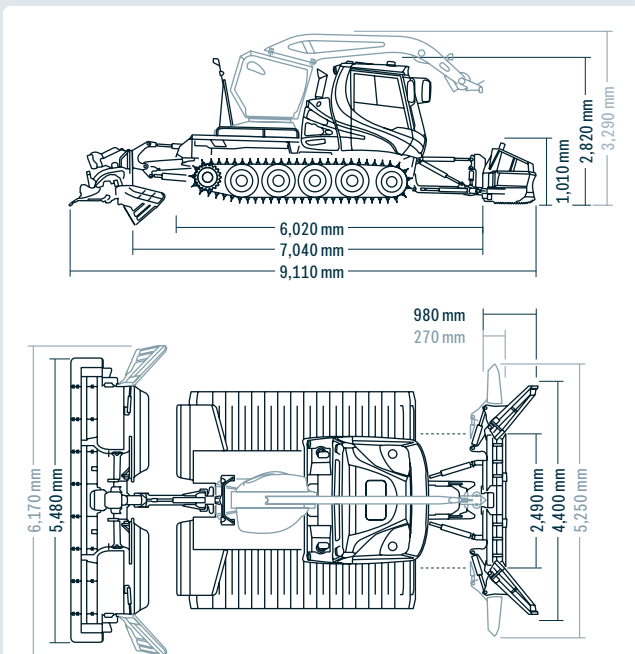

DIMENSIONS

Width	Without tracks and fenders	2,490 mm
	Over X-track tracks 1,150 mm	3,500 mm
	Over X-track tracks 1,420 mm	3,770 mm
Height	Over 6-belt CombiPlus Tracks 1,648 mm	4,210 mm
	Total Solo	2,820 mm
	Ready for operation via winch	3,290 mm
	Folded down via winch	3,020 mm
Loading platform	Width	1,920 mm
	Length	2,120 mm
Ground clearance		350 mm

WEIGHTS (FROM)

	400	400W	
Empty weight	Vehicle without tracks / quick-change system	5,980 kg	8,260 kg
	X-track chains 1,150 mm	1,360 kg	1,360 kg
	X-track chains 1,420 mm	2,040 kg	2,040 kg
Operating weight*	6-belt CombiPlus Tracks 1,648 mm	2,100 kg	2,100 kg
	Vehicle with CombiPlus Tracks / all way blade / tiller	from 9,940 kg	from 12,510 kg
Permitted gross weight (in accordance with ROPS)	13,500 kg	14,200 kg	
Payload, load platform	2,500 kg	2,500 kg	
Power-to-weight ratio	31.1 kg/kW	39.1 kg/kW	

*Minimum operating weight (according to standard)

ENGINE

Type	Cummins L9
Number of cylinders	6
Displacement	8,900 cm ³
Power in accordance with ECE	320 kW / 435 PS
Exhaust gas standard	Tier 4f/EU Stage V/China IV
Max. torque	1,846 Nm @ 1,500 rpm
Tank capacity Solo/winch	240 l
DEF (AdBlue®) tank capacity	36 l
Fuel consumption	from 19.5 l/h

DRIVING CHARACTERISTICS

	400	400W
Speed	0 – 21 km/h stepless	0 – 19 km/h stepless
Speed during winch operation		0 – 17 km/h
Climbing ability	Up to 100%	
Turning radius	On the spot	

ACTIVEMINCH 4.0 WINCH ATTACHMENT

Pulling force stepless, automatic	40 kN / 4 t
Rope diameter	11 mm
Rope length	1,050 m
Usable rope length	1,000 m
Calculated breaking load of the rope	135 kN / 13.8 t
Weight (winch, rope and mount)	2,090 kg



Contact

Fast. Direct. In person.
Find your contact person here.

www.pistenbully.com

 **KÄSSBOHRER ALL TERRAIN VEHICLES INC.**