

# PB 600 Polar ParkPro

The flagship attraction in the park.



## PRODUCT HIGHLIGHTS

- ⊕ Optimum power-to-weight ratio for maximum gradeability
- ⊕ Intuitive joystick for proportional control of 4 blade functions at the same time
- ⊕ iTerminal with touch display and color-coded function feedback of the active vehicle parts for easy operation
- ⊕ Storage of 4 driver settings with flexible joystick button assignment for park construction
- ⊕ Precise, proportional auxiliary hydraulics
- ⊕ Assistance systems like SlopeTracer and AutoTracer for ideal grooming results, side hold and maneuverability
- ⊕ Extended park rear attachments for optimized park construction and a clear view of the tiller
- ⊕ NoDeck version for the best view of the SmartCut tiller in park construction
- ⊕ Professional sound package with subwoofers and amplifiers
- ⊕ Optimized comfort seats for long journeys
- ⊕ Practical holders for backpack, tool and smartphone
- ⊕ The best panoramic view thanks to dimmable LED worklights, a rear camera and ramp mirrors

## CAB

Comfort heating system	With automatic function and stepless temperature adjustment
Park comfort driver's seat	Swivel seat with lordosis support, air-suspended, multiple mechanical and pneumatic adjustment positions, two-stage seat heating unit and seat ventilation, harness
Auxiliary seat	With shoulder lap belt
Control elements	Joystick for 4 simultaneous movements, iTerminal, armrest, drive control stick
Windows	Windshield and rear window heated, side windows sliding and heated
Outside mirrors	Heated and electrically adjustable, wide-angle
Wipers	Heated by engine coolant

## LIGHTING

Front	4 LED headlights 4 LED worklights 2 LED worklights (BladeFlap)
Rear	2 LED worklights 2 LED worklights (TillerFlap)
Sides (carrier frame)	2 LED worklights (SideFinder)
Cab roof	1 halogen or 1 LED searchlight

## AUXILIARY EQUIPMENT

ProBlade 4.7 m	OneTouchStraight function, SideCutter, transport tines
ProFlexTiller SmartCut 5.5 m	With SmartCut tiller teeth and finishers, freeze function, dimmable lighting and camera, all positions hydraulically adjustable
ProMount	Swap system with radial kinematics and towing installation for a greater movement radius in park construction

## OPTIONS

Trailer hitch	Tensioning axle for front attachment
Automatic luxury climate control system	Charge pressure reduction
Front high-pressure connection (technology package)	SnowSat fleet management and snow depth measurement with LiDAR
Hydraulic oil preheating	Auxiliary heating
Infotainment with Apple CarPlay and Android Auto	Standard platform (+260 mm length with mudguard)
Folding side rail (only for standard platform)	Additional tank 120 l (only for standard platform)
Steering wheel incl. additional tiller operating panel	

On Top of the Mountain since 1969.

**PistenBully®**

# PB 600 Polar ParkPro

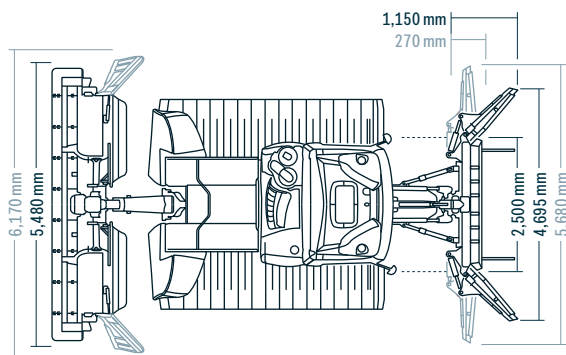
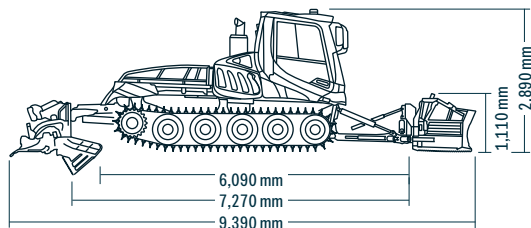

Power and torque of Cummins X12

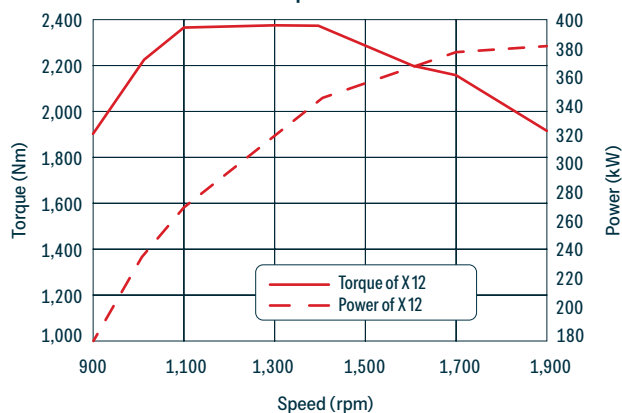

## DIMENSIONS

	Without tracks	2,500 mm
	Over X-track tracks 975 mm	3,150 mm
	Over X-track tracks 1,150 mm	3,500 mm
Width	Over X-track tracks 1,420 mm	3,770 mm
	Over 5-belt steel tracks 1,648 mm	4,210 mm
	Over 6-belt CombiPlus tracks 1,648 mm	4,210 mm
	Over 7-belt CombiPlus tracks 1,648 mm	4,210 mm
Height	Total Solo	2,890 mm
	With driver's cab tilted with rear camera	3,550 mm
Loading platform (in place of NoDeck)	Length	1,890 mm
	Width	1,920 mm
Ground clearance		350 mm

## WEIGHTS (FROM)

	Vehicle without tracks / quick-change system	6,845 kg
	X-track chains 975 mm	1,280 kg
	X-track chains 1,150 mm	1,455 kg
Empty weight	X-track chains 1,420 mm	2,120 kg
	5-steel tracks 1,648 mm	2,470 kg
	6-belt CombiPlus tracks 1,648 mm	2,200 kg
	7-belt CombiPlus tracks 1,648 mm	2,020 kg
Operating weight*	Vehicle with CombiPlus tracks/front blade/tiller	11,490 kg
Permitted gross weight (in accordance with ROPS)		13,500 kg
Payload of loading platform (optional)	NoDeck (1,500 kg)	
Power-to-weight ratio		30.1 kg/kW

\* Minimum operating weight (according to standard)

## ENGINE

Type	Cummins X12
Number of cylinders	6
Displacement	11,800 cm <sup>3</sup>
Power in accordance with ECE	382 kW / 520 hp (metric)
Exhaust gas standard	Tier 4f and EU Stage V
Max. torque	2,375 Nm @ 1,200 rpm
Tank capacity	300 l
DEF (AdBlue®) tank capacity	38 l
Fuel consumption	from 19.5 l/h

## DRIVING CHARACTERISTICS

Speed	Stepless from 0 - 21 km/h
Climbing ability	Up to 100%
Turning radius	On the spot



### Contact

Fast. Direct. In person.  
Find your contact person here.

[www.pistenbully.com](http://www.pistenbully.com)

 KÄSSBOHRER ALL TERRAIN VEHICLES INC.